

BE-970WM(NPL) vehicle CCTV monitor

User & fitting guide

User Guide & montage

User & Einbau Anleitung

Utente di montaggio e guida

Guía de usuario y montaje

User & montage handleiding

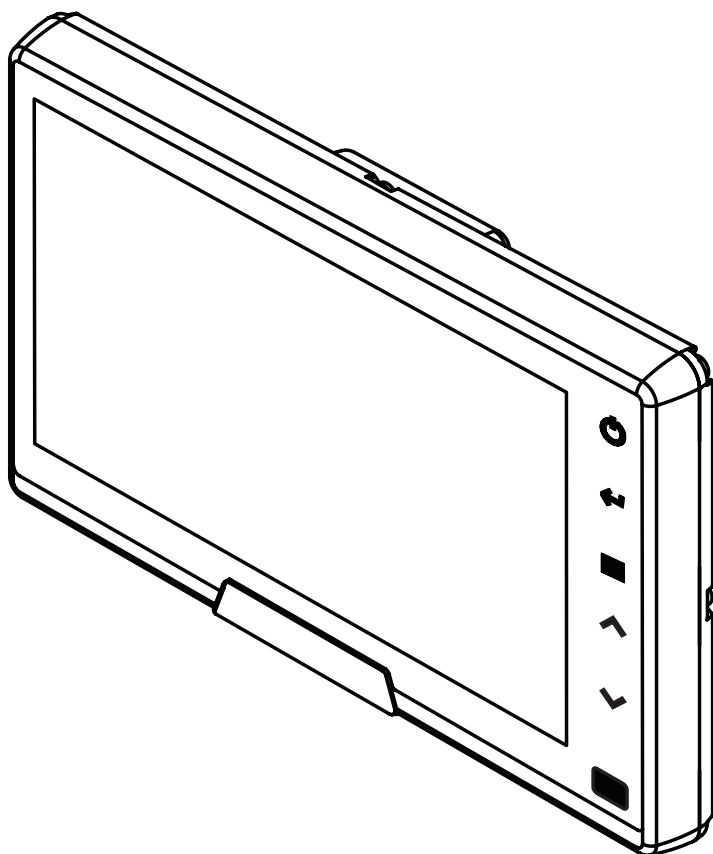

1 Contents/Contenu/Inhalt/Contenuti/Contenidos/inhoud

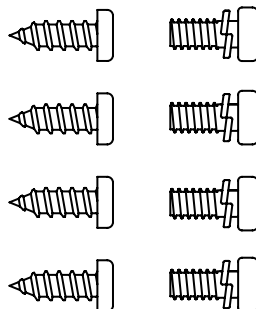
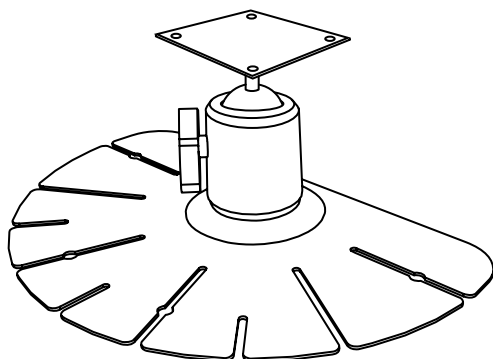
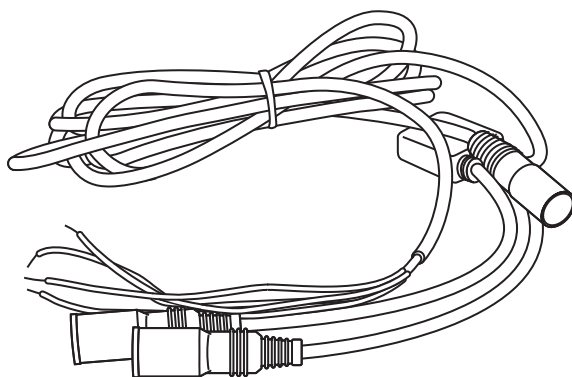
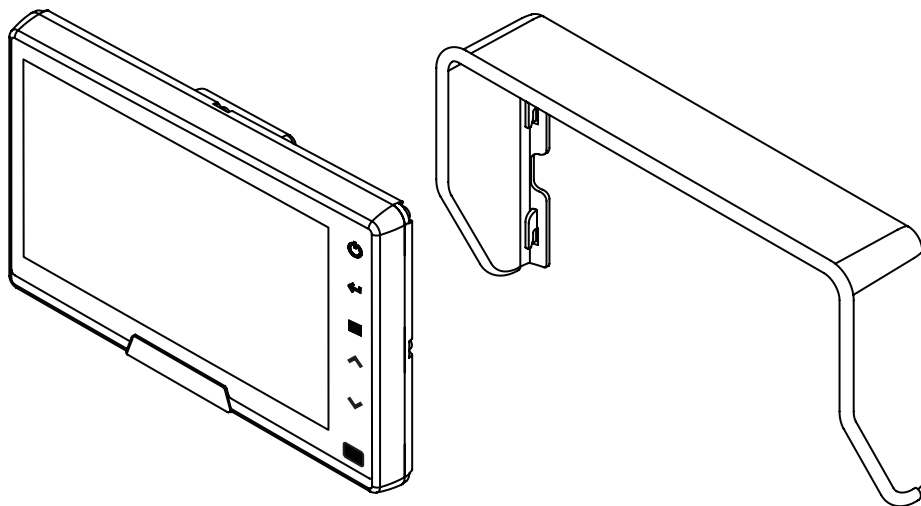

2 Monitor installation/Surveiller l'installation/ Monitor-Installation/L'installazione del monitor/ Vigilar la instalación/Monitor installatie

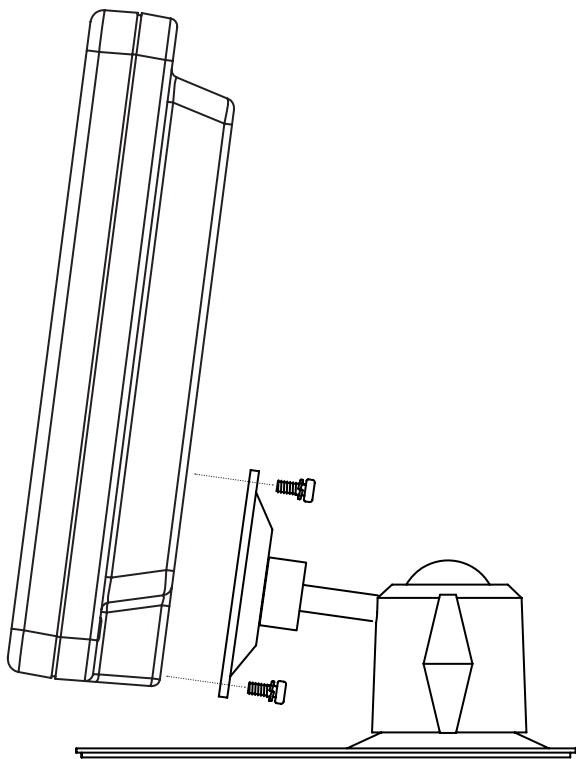
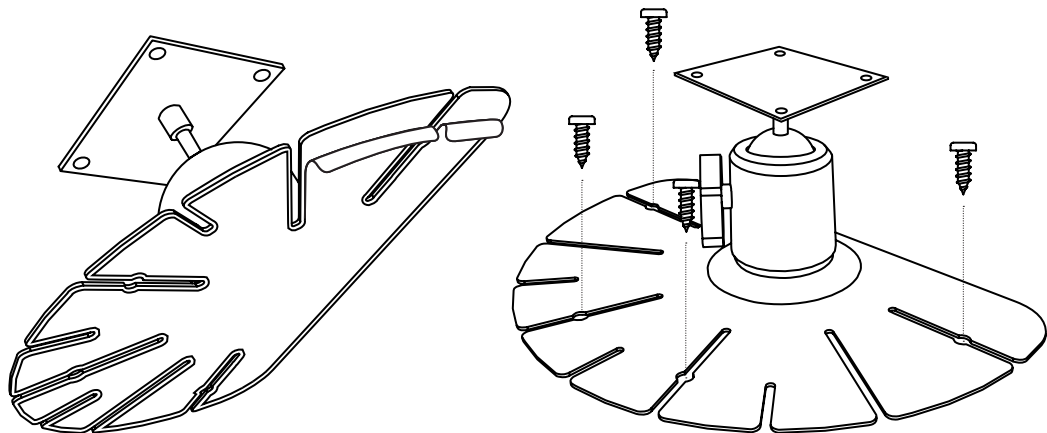

3 Connections/Connexions/Verbindungen/ Connessioni/Conexiones/Aansluitingen

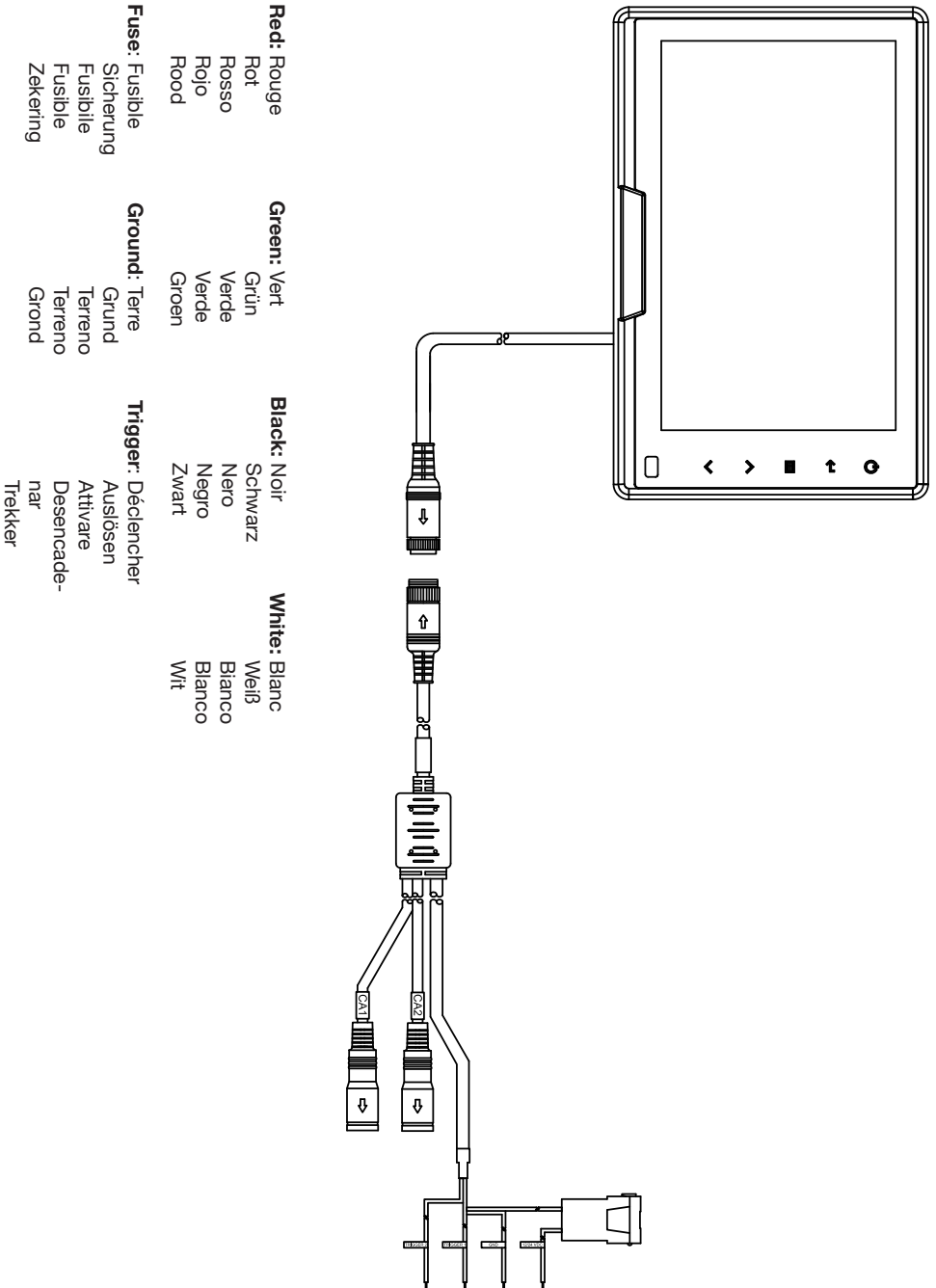

4 Controls/Contrôles/Kontrollen/Controlli/Controles/Controles

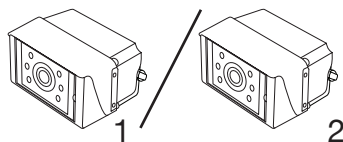
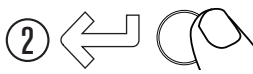
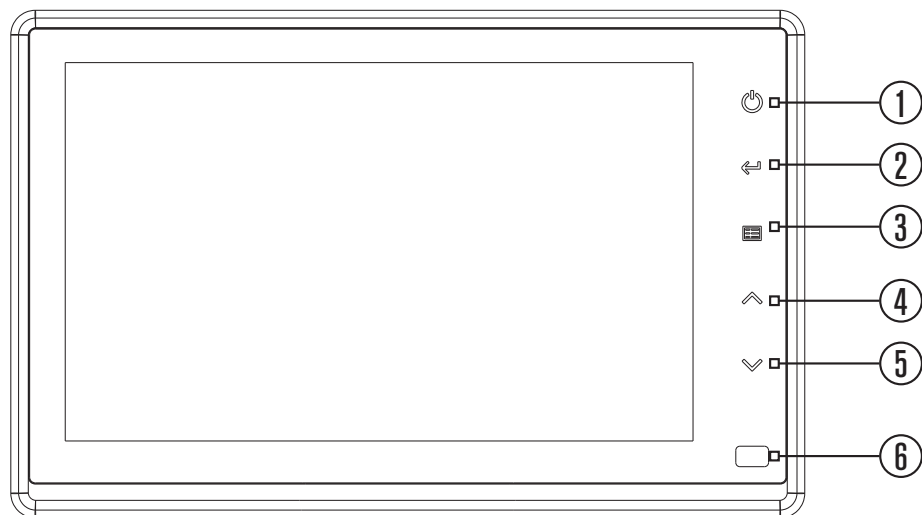

Automatic low light sensor - automatically adjusts monitor brightness.
Capteur optique automatique de basse luminosité - Réglage automatique de luminosité du moniteur
Automatischer Low-Light Sensor -passt Monitorhelligkeit automatisch an
Sensore automatico di bassa luminosità - varia automaticamente la luminosità dello schermo
Sensor automático de baja luminosidad - adapta automáticamente la luminosidad del monitor
Automatische low-light sensor - past de helderheid van de monitor automatisch aan

1 Controls/Contrôles/Kontrollen/Controlli/Controles/Controles

3



MENU



x1=

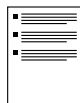

3



MENU



x 0.5sec



=



5



DOWN =



UP =



2 Operation/Opération/Betrieb/Operazione/Operación/ Werking

Auto Power ○/—



3 Set up menu/Menu setup/Setup Menü/Menu setup/Menú setup/Setup menu



- 1. CAMERA SETTING
- 2. TRIGGER SETTING
- 3. AUTO SCAN SETTING
- 4. DAY/NIGHT SETTING
- 5. **ADVANCED MENU**

- 1. **LANGUAGE: [ENGLISH;DEUTCH;FRANCAIS;ITALIANO;ESPANOL]**
- 2. AUTO POWER: [ON]
- 3. FACTORY RESET

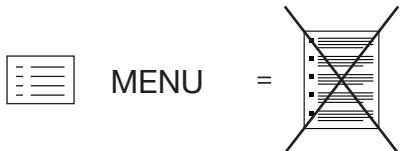

4 Specifications/Spécifications/ Spezifikationen/ Specifiche/Especificaciones/Specificaties

ENGLISH

Specifications	
Monitor	BE-970WM(NPL)
TV system	NTSC/PAL
Picture	7" TFT LCD colour monitor with on-screen display function
Display size	7" diagonal
Field of view	Top: 50°, Bottom: 60°, Left: 65°, Right: 65°
Resolution	(800x3(RGB)x480)
Picture image	Factory set to reverse image
Power	12~24Vdc input
Inputs	2 x camera
Dimensions	194(w) x 124(h) x 48(d)mm 7.6(w) x 4.9(h) x 1.9(d) inches
Operating temperature	-40°C ~ +70°C -40°F ~ +158°F

FRANCAIS

Specifications	
Moniteur	BE-970WM(NPL)
Système TV	NTSC/PAL
Image	7" TFT LCD moniteur couleur avec affichage de fonction (OSD)
Dimension de l'écran	7" diagonal
Champ de vision	Haut: 50°, Bas: 60°, Gauche: 65°, Droite: 65°
Résolution	(800x3(RGB)x480)
Image vidéo	Réglage d'usine sur image inverse
Alimentation	12~24Vdc input
Entrées	2 x caméra
Dimensions	194(w) x 124(h) x 48(d)mm 7,6(w) x 4,9(h) x 1,9(d) inches
Température d'utilisation	-40°C ~ +70°C -40°F ~ +158°F

ITALIANO

Specifiche	
Schermo	BE-970WM(NPL)
Sistema TV	NTSC/PAL
Immagine	7" TFT LCD colour monitor with on-screen display function
Formato display	7" diagonale
Campo visivo	Top: 50°, Bottom: 60°, Left: 65°, Right: 65°
Risoluzione	(800x3(RGB)x480)
Immagine a video	Immagine reversibile programmabile
Alimentazione	12~24Vdc input
Prese	2 x telecamera
Dimensioni	194(w) x 124(h) x 48(d)mm 7.6(w) x 4.9(h) x 1.9(d) inches
Temperatura di servizio	-40°C ~ +70°C -40°F ~ +158°F

DEUTSCH

Spezifikationen	
Monitor	BE-970WM(NPL)
TV-System	NTSC/PAL
Bild	7" TFT LCD Farbmonitor mit Funktionsanzeige (OSD)
Bildschirmgröße	7" diagonal
Sichtfeld	Oben: 50°, Unten: 60°, Links: 65°, Rechts: 65°
Auflösung	(800x3(RGB)x480)
Videobild	Werkseinstellung Reversebild
Stromversorgung	12~24Vdc input
Eingänge	2 x kamera
Abmessungen	194(w) x 124(h) x 48(d)mm 7.6(w) x 4.9(h) x 1.9(d) inches
Betriebstemperatur	-40°C ~ +70°C -40°F ~ +158°F

7 Specifications/Spécifications/Spesifikationen/ Specifiche/Especificaciones/Specificaties

ESPANOL	
Especificaciones	
Monitor	BE-970WM(NPL)
Sistema de TV	NTSC/PAL
Imagen	Monitor a color de 7" TFT LCD con visualización de las funciones (OSD)
Tamaño de pantalla	7" diagonal
Campo visual	arriba: 50°, abajo: 60°, a la izquierda: 65°, a la derecha: 65°
Resolución	(800x3(RGB)x480)
Imagen de vídeo	Ajuste de fábrica de la imagen inversa
Suministro de corriente	12~24Vdc entrada
Entradas	2 x cámara
Dimensiones	194(w) x 124(h) x 48(d)mm 7.6(w) x 4.9(h) x 1.2(d) inches
Temperatura de servicio	-40°C ~ +70°C -40°F ~ +158°F

NEDERLANDS	
Specificaties	
Monitor	BE-970WM(NPL)
TV-systeem	NTSC/PAL
Beeld	7" TFT LCD colour monitor with on-screen display function
Displayformaat	7" diagonaal
Gezichtsveld	Boven: 50°, Onder: 60°, Links: 65°, Rechts: 65°
Resolutie	(800x3(RGB)x480)
Videobeeld	Fabrieksinstelling reversebeeld
Stroomvoorziening	12~24Vdc Ingang
Ingangen	2 x camera
Afmetingen	194(w) x 124(h) x 48(d)mm 7.6(w) x 4.9(h) x 1.2(d) inches
Bedrijfstemperatuur	-40°C ~ +70°C -40°F ~ +158°F

Specifications subject to change. Sous réserve de modifications techniques. Vorbehallich technischer Änderungen. Con riserva di modifichite tecniche. Reservadas las modificaciones técnicas. Technische wijzigingen voorbehouden.

Disclaimer

Camera monitor systems are an invaluable driver aid but do not exempt the driver from taking every normal precaution when conducting a manoeuvre. No liability arising out of the use or failure of the product can in any way be attached to the distributor.

Dénégation

Les systèmes de moniteurs des caméras sont une aide précieuse pour le conducteur, mais celui-ci doit toutefois prendre toutes les précautions nécessaires pendant les manœuvres. Ses distributeurs n'assument aucune responsabilité résultant de l'utilisation ou d'un défaut du produit.

Verzichtklärung

Die Kamerabildschirmssysteme sind eine wertvolle Hilfe für den Fahrer, entbinden ihn jedoch nicht von der notwendigen Sorgfalt beim Manövrieren des Fahrzeuges. Vertriebshändler haften nicht für Schäden aus der Nutzung oder einer Fehlfunktion des Produktes.

Disconoscimento

I sistemi di monitor della telecamera sono un aiuto prezioso per il conduttore, ma non lo esonerano dall'obbligo di prendere le precauzioni necessarie durante le manovre del veicolo. Distributori non si assumono nessuna responsabilità per danni risultanti dall'utilizzo o da un malfunzionamento del prodotto.

Negante

Los sistemas de pantalla de cámara son una valiosa ayuda destinada a los conductores; en todo caso no les resta la responsabilidad de proceder con precaución a la hora de maniobrar con el vehículo. Distribuidores comerciales no se responsabilizan de los daños derivados de un mal funcionamiento del producto.

Verwerping

De camera-monitorsystemen zijn een waardevolle hulp voor de bestuurder, ontheffen hem echter niet van de nodige zorgvuldigheid bij het manoeuvreren van het voertuig. Het distributeurs zijn niet aansprakelijk voor schade door gebruik of een gebrek van het product.

Serial No:

Part No: